



centor

E4 bifold door hardware for panels to 120kg
E4S sliding door hardware for panels to 400kg

CONTENTS

Centor E4

Engineered Excellence 1

High Performance Results 2

Effortless Operation 3

Proven Durability 4

E4 Up Close 5

E4 Assurance 6

Centor Lifestyle Options 7

E4 Product Details 8

Architectural Details 9

Component Selection 12

Dropbolts 17

Surelock™ Adjustment 20

Common Panel Layouts 21

Centor E4S

Startling Carrying Capacity 24

E4S Up Close 25

E4S Product details 26

Component Selection 27

TALLER, WIDER DOOR PANELS, EXPANSES OF FRAMED GLASS



ENGINEERED EXCELLENCE

One moment bifold doors are acting as an effective, secure barrier from rain, wind and noise. The next they're effortlessly moved aside to reveal wide open space – with no fixed glass panels or posts. E4's massive weight-bearing capacity sets new standards for functional, stylish ways of bringing the outdoors in. Possible applications for Centor's bifold range are limited only by the imaginations of the world's most progressive architects and designers.

Engineered to withstand the most severe weather, E4 is just as suited to interior use where the ability to visually and physically connect spaces can be equally beneficial and the sound-proofing effect of double-glazing just as important. The benefits to the end-user in flexibly managing interior or exterior space to suit lifestyle or business are literally changing the face of contemporary building design.

E4 Specifications

max opening width	17600mm
max panel weight	120kg
max panel height	4000mm
max panel width	1100mm
min panel thickness	45mm
max number of panels	16 (8 each direction)

RELY ON CENTOR-GRADE PERFORMANCE WITH WEATHERSEALED E4



HIGH PERFORMANCE RESULTS

Internal environment, operational function, durability, painstaking attention to detail and an unerring commitment to quality mean 'Centor-grade' performance, whatever the category. The result is a degree of control and comfort for the end-user that matches the easy flexibility of modern design.

Interior Comfort

E4 is truly a system for all seasons and all locations. Teamed with quality door panels, E4 hardware ensures a formidable barrier against the elements when closed. The integrity of the required interior environment is never compromised.

Rain and Wind

Centor hardware was utilised in the first tracked bifold door system to be certified under Australian Standard AS2047, which specifies the weather performance required of external windows and sliding doors. Doors utilising the E4 system have since passed all tests required for product approval from Florida's meticulous Miami-Dade County testing authorities – the single toughest standard of testing anywhere in the world in a region legendary for its coastal hurricanes and seasonal weather. This means driving rain and howling gales can be shut out completely with the tough E4 system.

Air Infiltration

The E4 system achieves its superior rain and wind resistance in part from the way it allows the folding doors to close snugly against weather seals. In the same way doors using E4 effectively resist air infiltration to a level up to 50 times better than a conventional sliding door.

Noise and Temperature

With double glazing allowed for by E4's impressive panel weight capacity, unprecedented levels of insulation against noise and temperature variation are possible.



EFFORTLESS OPERATION

While E4's outstanding performance as part of a secure, weatherproof barrier is crucial, it's not until the doors are opened that the space-transforming benefits of the system truly come into play. For maximum enjoyment and use of the system, every effort has been made to ensure that doors glide open and slide shut with the minimum of effort throughout their working life.

Quality Manufacture, Clever Design

E4 carriers, guides and pivots use stainless steel bearings custom machined to extremely fine tolerances on state-of-the-art German and Swiss machinery. Machined wheels are individually precision ground while innovative carrier design prevents scraping on the inside of the overhead track.

Assembly and Installation

Assembly and installation couldn't be easier. Comprehensive instructions are included to ensure precise placement of fittings.

Adjustment

While E4 is designed to operate flawlessly well into the future, built-in adjustment mechanisms make the system tolerant of an imperfect world. Surelock II™, Centor's patented carrier pin locking system ensures that once heights are set they stay set. Should door panels swell or a newly built structure settle over time, the end-user can make vertical and lateral adjustments simply using a screwdriver or Allen key.

Collaborative Design Process

E4's thoughtful design doesn't achieve the highest performance in all categories on its own. It's in its element teamed with the quality products created by Centor's many manufacturing and custom fabricating clients. The Centor technical department can assist in the design process for door sets incorporating the E4 system to ensure that the highest criteria for completed and installed doors are met even in the most unusual applications.

TOUGH TESTING CONDITIONS FOR HIGH STANDARDS OF DURABILITY



PROVEN DURABILITY

While Centor Architectural certainly enjoys its reputation for innovation, ensuring that products meet and exceed the highest standards for durability is just as much a passion. This means a significant investment in repeatedly testing systems under the toughest of conditions – then testing them again.

Laboratory Testing

In addition to extensive weather testing as part of complete door systems, all individual E4 components have been extensively laboratory tested, ensuring years of trouble-free use from hardware which ages with grace.

Cyclic Testing

Centor's minimum requirement of cyclic testing for this product is a grueling 50,000 cycles without a single failure and E4 has been tested in excess of 50,000 cycles without failure or loss of function.

Corrosion Testing

Stainless steel and engineering-grade plastics are used throughout the E4 system and are carefully selected to maximise performance in any environment. Centor conducts regular, thorough corrosion testing in a salt spray chamber, fixing hardware to various substrates to ensure that E4 will perform admirably even in the most exposed of coastal applications.

Structural Testing

As might be expected from a truly heavy-duty system, E4's tested strength is exceptional.

In the course of obtaining approval under the stringent Miami-Dade County testing regime, doors based on the E4 system were subjected to hurricane strength wind loads, flexing the doors in and out five thousand times without component failure. Small and large missile impact testing was also performed as part of the single toughest testing process anywhere in the world.

Finite Element Analysis

Finite Element Analysis (FEA) is a computerised simulation technique where products are exposed to virtual operating environments and accurate predictions made in terms of load and deflection. Centor undertakes FEA in the design process to ensure the best balance of performance, cost and materials in every system.



E4 UP CLOSE

Even a casual glance at the E4 system gives a strong impression of Centor's commitment to quality, but it's only upon closer inspection that the attention to detail really becomes apparent. Behind E4's tough good looks and robust proportions is a system stacked with standard features and flexible options to choose from. It's a system that looks even better up close.

Materials and Finishes

E4 carriers, guides, pivots and hinges are available in brushed stainless steel or oil rubbed bronze powdercoat on request. Head tracks and sills are produced in extruded aluminium, in natural anodised and custom powdercoat finish. Floor guide channels are produced in extruded aluminium, in natural anodised or custom powdercoat finish. Weatherseals are available in brown, black and white.

Panel Size and Materials

Centor's innovative hinge system enables the use of uniform-sized door panels regardless of the door configuration ensuring maximum efficiency in door manufacture. Easily installed hardware can be teamed with standard door panels in timber, aluminium, PVC or fiberglass. Maximum panel weight of 120kg means panel construction from the sturdiest of materials is possible.

Design Features

Top-rolling function means superior performance which is never compromised by the issue of debris in tracks. A floating wall pivot is used to control door stile deflection and bowing on tall doors caused by wind loads or climatic conditions. The type of tall, heavy doors typically used with the E4 system will generally require four hinges at each junction to maintain alignment of panels and seals.

Dropbolts

Easily installed with a dedicated router bit available from Centor, DF and DO dropbolts are available in a range of lengths and finishes to suit every E4 application. Available keyed and non-keyed, the clean-lined DF and DO dropbolts anchor doors firmly in the closed position. Together with the weather seals, they eliminate rattling in strong winds.



E4 ASSURANCE

If success in modern design can be measured by the degree of comfort and ease afforded to the end-user, then Centor E4 again rates highly. E4's superior function and performance goes a long way to creating a relaxed setting, while a range of other measures allow the system to be utilised with complete confidence.

Unparalleled Security

The E4 system responds to an increasingly security conscious market place with measures designed to ensure unwanted visitors are excluded – as well as the elements.

Concealed Fittings

When doors utilising E4 are closed there are no externally accessible parts that can be removed or damaged. Screw fixings are concealed and hinge caps are retained by hidden fasteners.

Locking Screw Technology

The E4 system incorporates locking screw technology which ensures the E4 hardware cannot be removed from the track when the doors are closed.

Specifying E4

For detailed component selection, including calculating size and number of door panels, specifiers can utilise Doorcalc, Centor's free specification and ordering software. Doorcalc is available from www.centor.com.au

Architects and designers can feel comfortable simply specifying 'Centor E4' and leaving detailed component selection to the builder, joiner or fabricator.

Warranty

In line with a commitment to the highest possible quality Centor offers a 10-year warranty on E4 hardware.



WINDOW & DOOR HARDWARE CREATED FOR REAL LIFE SITUATIONS



CENTOR LIFESTYLE OPTIONS

Centor Folding

Based on the same functional geometry but with distinctive capacity and features, Centor's internal and external bifold range offers an alternative for every application. From the smallest folding window to four metre high walls of glass which fold away in seconds, Centor bifold systems create a formidable barrier against the elements, yet glide open with finger-tip ease.

EW and E2 are the mainstays of this flexible product range. Developed first and constantly upgraded since their inception they remain the perfect choice for the private residence or lighter commercial application. E2i is Centor's internal bifold system which has no sill or guide channel, allowing for seamless transitions between indoor spaces.

E3 and E4 are Centor's responses to the demands of architects and consumers wishing to expand the potential of bifold innovation into heavier-duty residential and commercial applications. E3 doubles the panel weight capacity of the E2 system, making

even sturdier panel materials and double glazing possible. The E4 system takes it even further with a massive 120kg panel weight capacity and substantially increased height, width and overall measurement specifications, ensuring that Centor bifold systems remain the perfect choice for every project.

Centor Screening

The award-winning S1E Eco-Screen™ is the latest innovation from Centor. Available with insect screen or solar control blind fabrics up to 3.2 metres high and 7.6 metres wide, S1E may be used with E4-based doors.

E4 PRODUCT DETAILS

Downloadable DXF or DWG files ready for use in your own documentation are a convenient resource for architects and specifiers wishing to use Centor systems.

E4 DXF or DWG files can be downloaded from www.centor.com.au

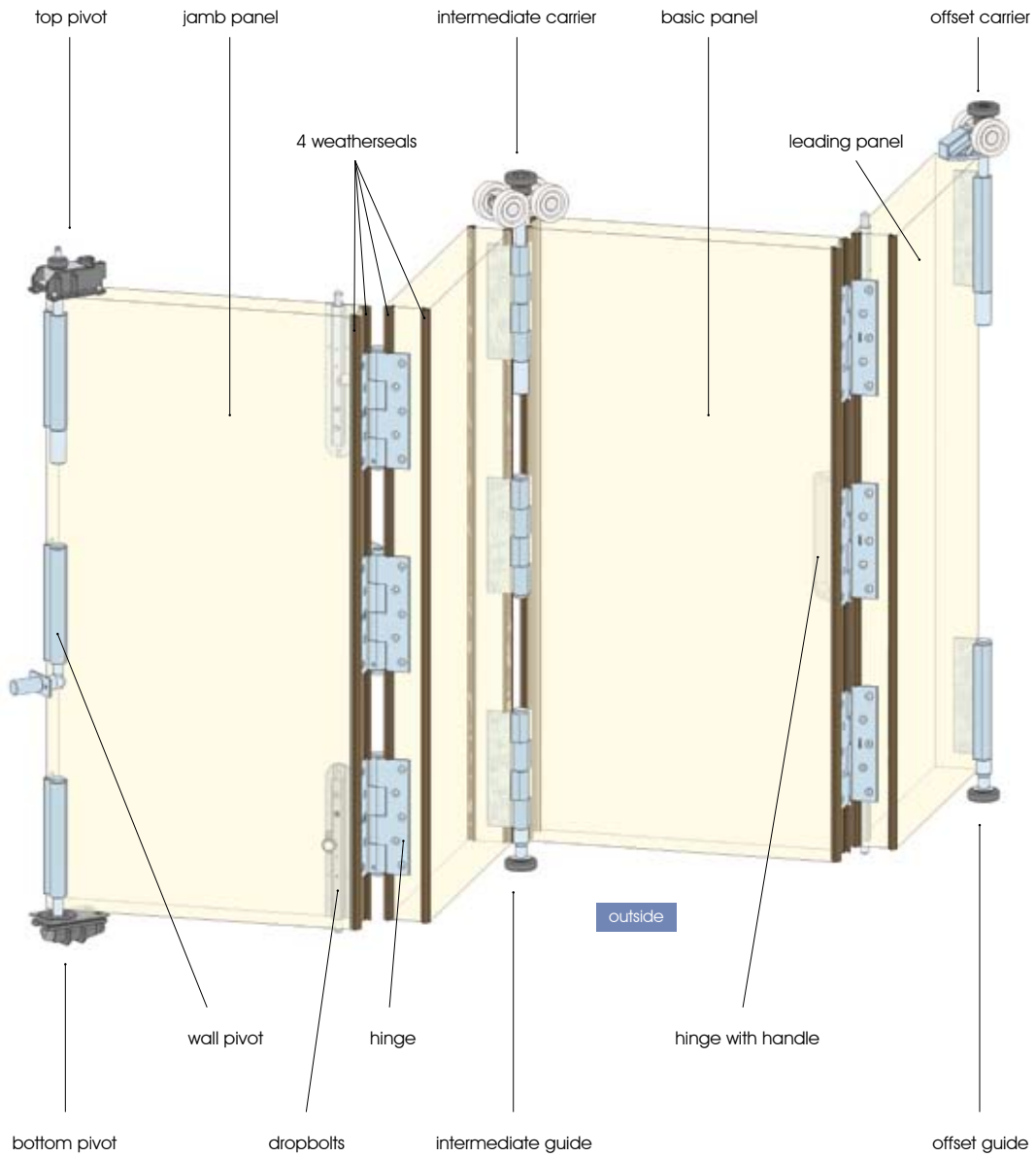

E4 ARCHITECTURAL DETAIL

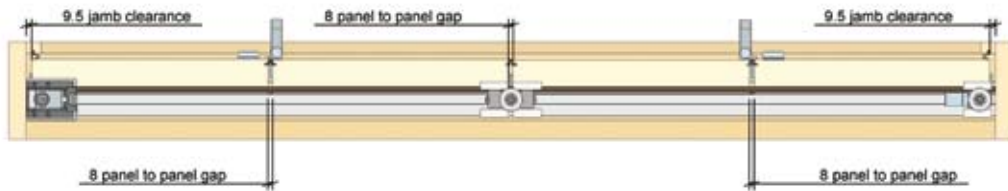

E4-001.DXF

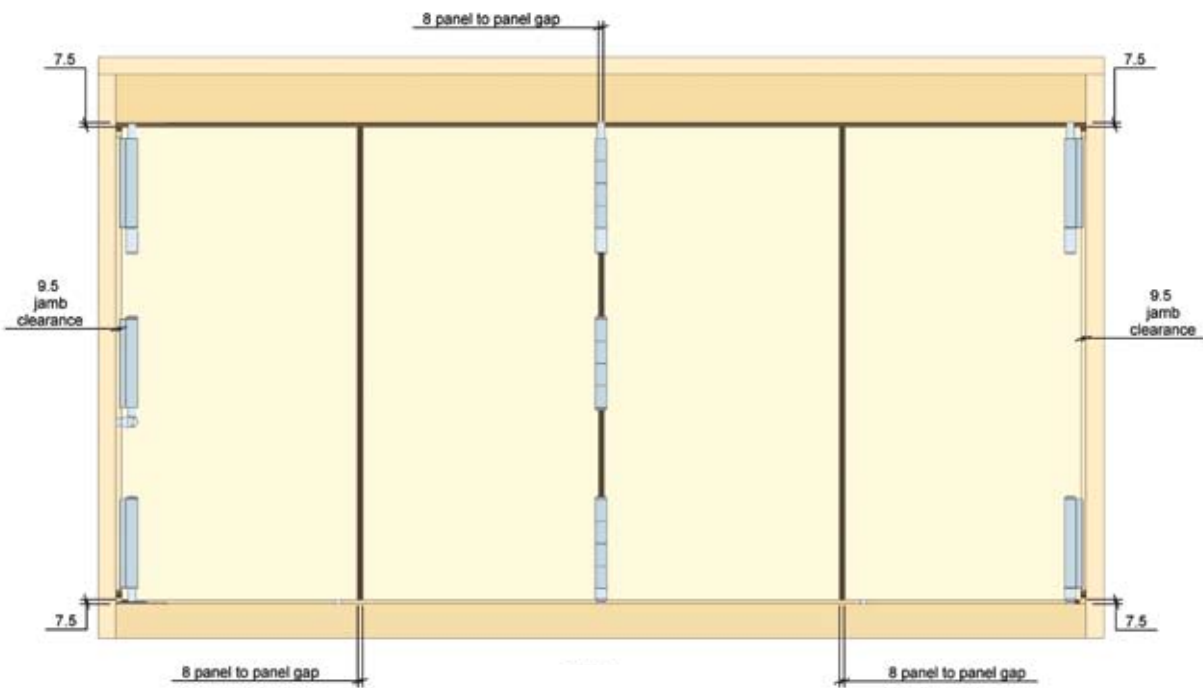

E4-002.DXF

E4 ARCHITECTURAL DETAIL

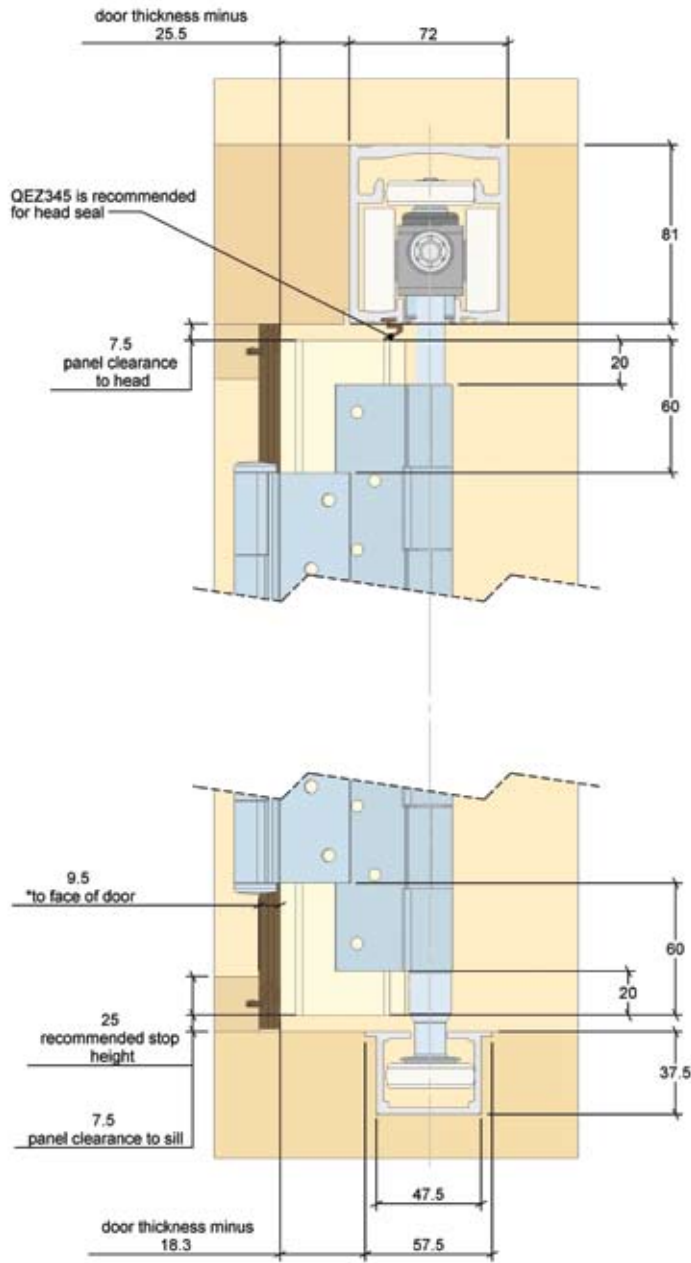

* recommended seal is E4QLS

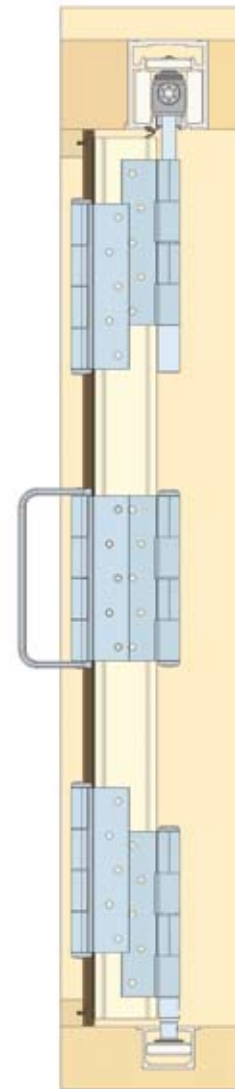

E4-004.DXF

E4 ARCHITECTURAL DETAIL

Equal Sized Panels

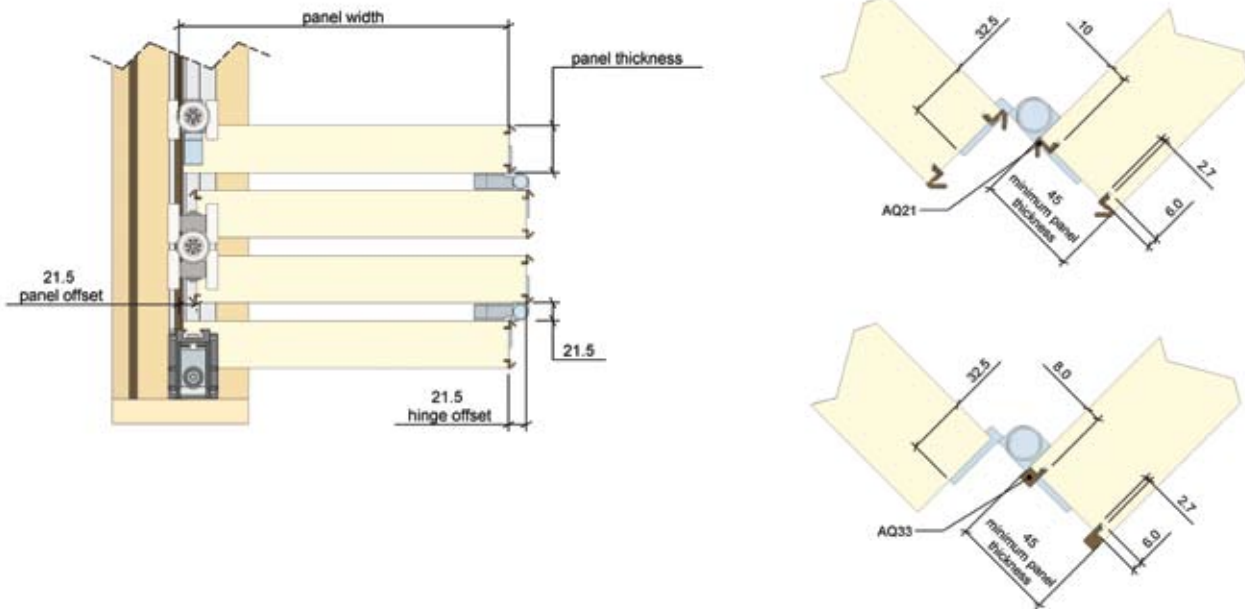

E4-OO3.DXF

E4 Jamb for 57.2mm Door Thickness (typical)

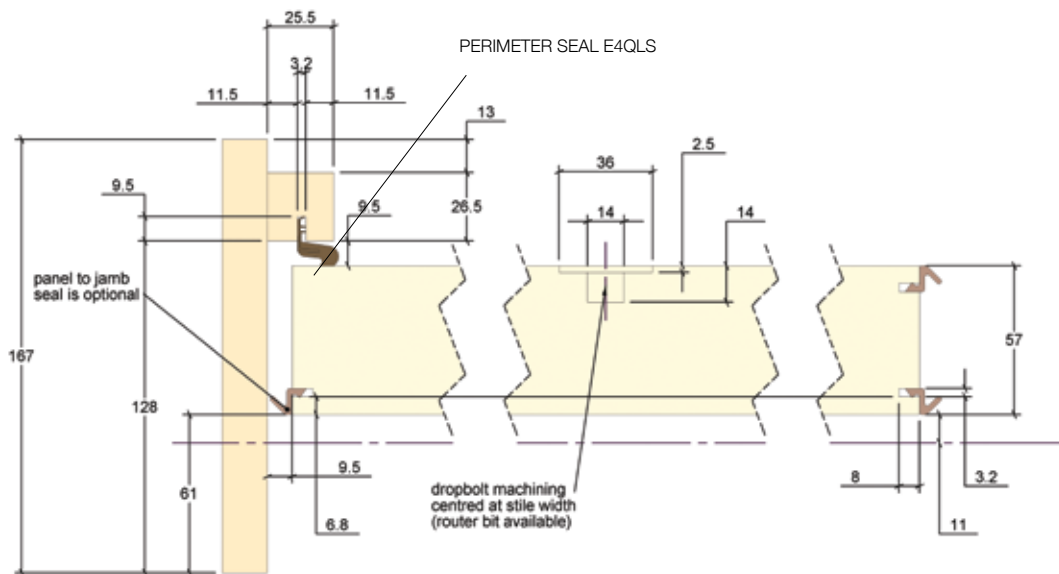

E4 COMPONENT SELECTION

E4 is specified with 5 separate component groups. Components are required from each group to build an E4 folding door system.

- 1 **Track** – choose surface finish and size required to suit opening
- 2 **Sill Assembly** – choose a pre-assembled Centor sill with surface finish, floor guide type and size to suit opening
- 3 **Door Hardware Sets** – choose surface finish, floor guide type and sets required to suit panel layout
- 4 **Dropbolts** – choose surface finish, type, size & number required to suit panel layout
- 5 **Weather Seals** – choose colour, type and amount of each seal required to suit opening size and panel layout

TRACK



PART	TRACK	PRODUCT CODE	DESCRIPTION
	aluminium track, machined	E4TM4N	4000mm machined track, natural anodised
		E4TM6N	5700mm machined track, natural anodised

CHANNEL SELECTION

PART	CHANNEL	PRODUCT CODE	DESCRIPTION
	aluminium floor channel pre-machined	E4FCM4N	4000mm machined channel, natural anodised
		E4FCM6N	5700mm machined channel, natural anodised

E4 COMPONENT SELECTION

INTERMEDIATE CARRIER SET

PART	PARTS ON PANELS	PRODUCT CODE	DESCRIPTION
		E4ICSS E4ICSQ	intermediate carrier set, stainless steel intermediate carrier set, oil rubbed bronze powdercoat*

* Longer lead times apply. Please contact Centor for details.

OFFSET CARRIER SET



PART	PARTS ON PANELS	PRODUCT CODE	DESCRIPTION
		E4OCSS E4OCSQ	offset carrier set, stainless steel offset carrier set, oil rubbed bronze powdercoat*

* Longer lead times apply. Please contact Centor for details.

E4 COMPONENT SELECTION

PIVOT SET – WALL PIVOT

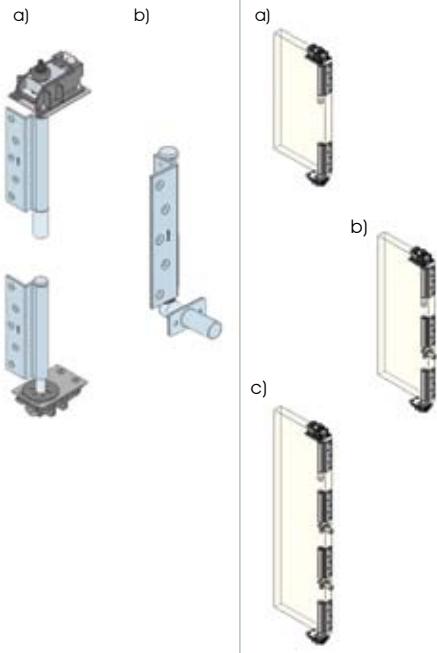
Wall pivots are recommended on door panels over 2250mm. Wall pivots are strongly recommended on all door panels in wet or humid climates, exposed locations, inward opening applications and unstable timber doors. On very tall doors with four hinges second pivot can be used on door panels to match the additional row of hinges.



PART	PARTS ON PANELS	PRODUCT CODE	DESCRIPTION
		E4PSS	adjustable pivot set, stainless steel
		E4PSQ	adjustable pivot set, oil rubbed bronze powdercoat*
		E4WPS	wall pivot set, stainless steel
		E4WPQ	wall pivot set, oil rubbed bronze powdercoat*

a) pivot set

b) pivot set and jamb mounted middle wall pivot recommended on door panels over 2250mm to prevent/control deflection and bowing

c) pivot set and jamb mounted two middle wall pivots recommended for door panels over 2750mm



HALF OFFSET HINGE SET

PART	PARTS ON PANELS	PRODUCT CODE	DESCRIPTION
		E4HHSS	half offset hinge set, stainless steel
		E4HHSQ	half offset hinge set, oil rubbed bronze powdercoat*

* Longer lead times apply. Please contact Centor for details.



E4 COMPONENT SELECTION

STRAIGHT HINGE SET

PART	PARTS ON PANELS	PRODUCT CODE	DESCRIPTION
		E4HSS	straight hinge set, stainless steel
		E4HSQ	straight hinge set, oil rubbed bronze powdercoat*



* Longer lead times apply. Please contact Centor for details.

SINGLE HALF OFFSET HINGE (recommended for doors over 2250mm)

PART	PARTS ON PANELS	PRODUCT CODE	DESCRIPTION
		E4HHNHS	hinge, stainless steel
		E4HHNHQ	hinge, oil rubbed bronze powdercoat*

* Longer lead times apply. Please contact Centor for details.



SINGLE STRAIGHT HINGE (recommended for doors over 2250mm)

PART	PARTS ON PANELS	PRODUCT CODE	DESCRIPTION
		E4HS	hinge, stainless steel
		E4HQ	hinge, oil rubbed bronze powdercoat*



* Longer lead times apply. Please contact Centor for details.

E4 COMPONENT SELECTION

WEATHERSEALS AND ASTRAGAL SELECTION

PART	PRODUCT CODE	DESCRIPTION
	AQ21B	Schlegel Aquamac 21, brown
	AQ21L	Schlegel Aquamac 21, black
	AQ21W	Schlegel Aquamac 21, white
	E4QLSB	Schlegel Q-Ion perimeter seal, brown
	E4QLSW	Schlegel Q-Ion perimeter seal, white

WEATHERSEAL ALTERNATE SELECTION

PART	PRODUCT CODE	DESCRIPTION
	AQ33B	Schlegel Aquamac 33, brown
	AQ33L	Schlegel Aquamac 33, black
	AQ33W	Schlegel Aquamac 33, white
	AQ109B	Schlegel Aquamac 109, brown
	AQ109L	Schlegel Aquamac 109, black
	AQ109W	Schlegel Aquamac 109, white

AVAILABLE IN A RANGE OF LENGTHS AND FINISHES



DROPBOLTS

Centor's stylish, flush-mounting dropbolts are the ideal solution for fastening or securing bifold doors based on the E4 system. Easily installed with a dedicated router bit available from Centor, DF and DO dropbolts are available in a range of lengths and finishes to suit many applications. The bolts are available keyed alike and may be re-keyed by a professional locksmith.

Centor DF

Rated to resist the most extreme wind conditions (up to 450kg force in certain timbers) DF dropbolts feature rounded styling and are suited to use with outward opening bifold doors, french doors and sliding doors. Available in 200mm, 400mm, 600mm and 1000mm lengths with a 20mm throw they come in natural and gold anodised, chrome, brushed metallic and custom powdercoated finishes. Keyed DF dropbolts feature a unique bifold damage-proofing mechanism which prevents the bolt being operated while the key remains in the lock.

Centor DO

Designed specifically for use with inward opening bifold doors Centor DO comes into its own wherever an offset bolt is required, features an extended 20mm throw. Rated to resist wind conditions up to 200kg force in certain timbers, DO is available in 200mm, 400mm and 600mm lengths. Do comes in natural and gold anodised and brushed metallic finishes. Keyed DO dropbolts feature a unique bifold damage-proofing mechanism which prevents the bolt being operated while the key remains in the lock.



Centor DF dropbolt



Centor DO dropbolt

DROPBOLTS / OUTWARD OPENING

DF – KEYED

PART	PRODUCT CODE	DESCRIPTION
	DBFO200KRN	200mm dropbolt, keyed, natural anodised
	DBFO200KRG	200mm dropbolt, keyed, gold anodised
	DBFO200KRL	200mm dropbolt, keyed, black powdercoat
	DBFO200KRW	200mm dropbolt, keyed, white powdercoat
	DBFO200KRPC	200mm dropbolt, keyed, custom powdercoat
	DBFO200KRX	200mm dropbolt, keyed, brushed metallic
	DBFO200KRC	200mm dropbolt, keyed, chrome
	DBFO400KRN	400mm dropbolt, keyed, natural anodised
	DBFO400KRG	400mm dropbolt, keyed, gold anodised
	DBFO400KRX	400mm dropbolt, keyed, brushed metallic
	DBFO600KRN	600mm dropbolt, keyed, natural anodised
	DBFO600KRG	600mm dropbolt, keyed, gold anodised
	DBFO600KRX	600mm dropbolt, keyed, brushed metallic
	DBFO1000KRN	1000mm dropbolt, keyed, natural anodised
	DBFO1000KRX	1000mm dropbolt, keyed, brushed metallic

Custom powdercoat available by special order

DF – NON-KEYED

PART	PRODUCT CODE	DESCRIPTION
	DBFO200NRN	200mm dropbolt, non-keyed, natural anodised
	DBFO200NRG	200mm dropbolt, non-keyed, gold anodised
	DBFO200NRL	200mm dropbolt, non-keyed, black powdercoat
	DBFO200NRW	200mm dropbolt, non-keyed, white powdercoat
	DBFO200NRPC	200mm dropbolt, non-keyed, custom powdercoat
	DBFO200NRC	200mm dropbolt, non-keyed, chrome
	DBFO200NRX	200mm dropbolt, non-keyed, brushed metallic
	DBFO400NRN	400mm dropbolt, non-keyed, natural anodised
	DBFO400NRG	400mm dropbolt, non-keyed, gold anodised
	DBFO400NRX	400mm dropbolt, non-keyed, brushed metallic
	DBFO600NRN	600mm dropbolt, non-keyed, natural anodised
	DBFO600NRG	600mm dropbolt, non-keyed, gold anodised
	DBFO600NRX	600mm dropbolt, non-keyed, brushed metallic
	DBFO1000NRN	1000mm dropbolt, non-keyed, natural anodised
	DBFO1000NRX	1000mm dropbolt, non-keyed, brushed metallic

Custom powdercoat available by special order

DROPBOLTS / INWARD OPENING

DOe – KEYED

PARTS	PRODUCT CODE	DESCRIPTION
	DBOE200KRN	200mm dropbolt, keyed, natural anodised
	DBOE200KRG	200mm dropbolt, keyed, gold anodised
	DBOE200KRX	200mm dropbolt, keyed, brushed metallic

DOe – NON-KEYED

PARTS	PRODUCT CODE	DESCRIPTION
	DBOE200NRN	200mm dropbolt, non-keyed, natural anodised
	DBOE200NRG	200mm dropbolt, non-keyed, gold anodised
	DBOE200NRX	200mm dropbolt, non-keyed, brushed metallic
	DBOE400NRN	400mm dropbolt, non-keyed, natural anodised
	DBOE400NRG	400mm dropbolt, non-keyed, gold anodised
	DBOE400NRX	400mm dropbolt, non-keyed, brushed metallic
	DBOE600NRN	600mm dropbolt, non-keyed, natural anodised
	DBOE600NRG	600mm dropbolt, non-keyed, gold anodised
	DBOE600NRX	600mm dropbolt, non-keyed, brushed metallic
	DBOE1000NRN	1000mm dropbolt, non-keyed, natural anodised
	DBOE1000NRG	1000mm dropbolt, non-keyed, gold anodised
	DBOE1000NRX	1000mm dropbolt, non-keyed, brushed metallic

SURELOCK II ADJUSTMENT™

E4 hardware has been designed for large, heavy doors which inevitably will also be tall. The ability to conveniently adjust and set the heights of such door panels has been given careful consideration. The Sure-Lock II™ allows easy adjustment with the Allen Key provided.

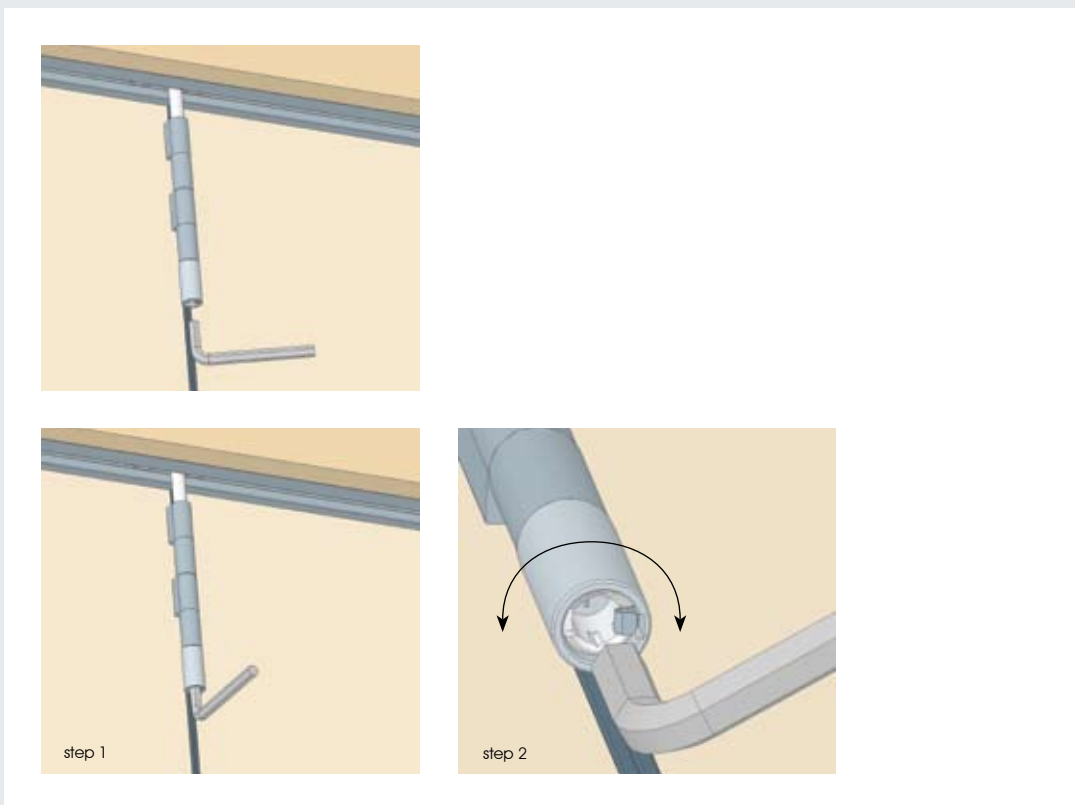

This stainless steel Surelock II™ mechanism has three significant features:

- 1 Adjusting the height setting requires only a single tool, a 9.5mm / (3/8") Hexagon Allen Key, in a single-handed operation. There is no need to hold or steady the Surelock II™ while the adjustment is being made. An Allen Key is provided with E4 pivot sets.
- 2 Insertion of the key disengages the self-locking spring latch. Once adjusted, the new setting is locked into place simply by allowing the latch to fall back into the locating slot as the key is removed.
- 3 A retaining screw limits the travel of the Sure-Lock II™ so that it cannot be adjusted to a structurally unsafe position.

E4 COMMON PANEL LAYOUTS

HARDWARE LEGEND	
PS	pivot set
WPS	wall pivot set
ICS	intermediate carrier set
OCS	offset carrier set (reversible)
HS	straight hinge set
HHS	half offset hinge set
DB	dropbolt

LEGEND	
Lock set	
Handles / Lock sets refer to Centor Door Furniture at www.centor.com.au	
Dropbolts top and bottom	

Note> Wall Pivot Set recommended for doors over 2250mm in height.

HARDWARE APPLICATION (3L2R)

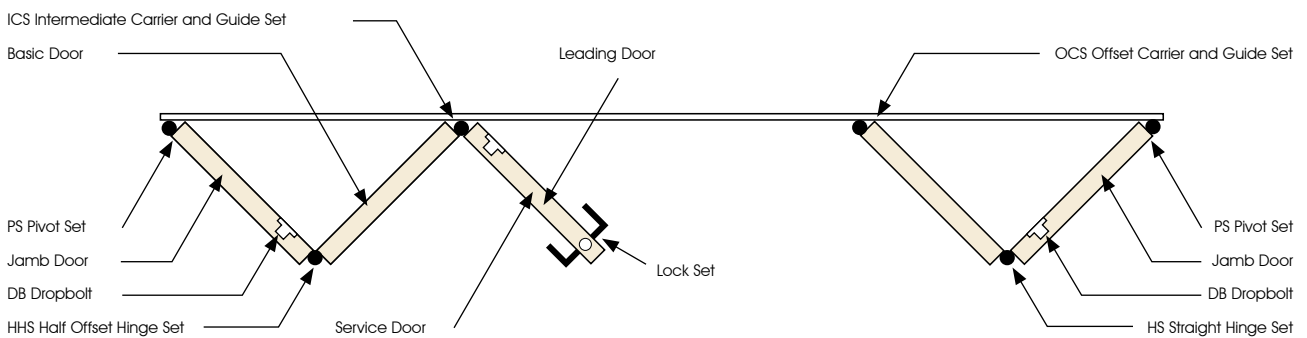

FLOATING DOOR PAIRS

Per pair of doors
 2 x offset carrier set
 1 x hinge set

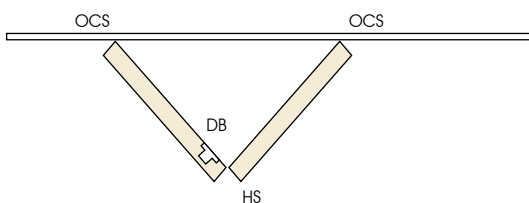

E4 COMMON PANEL LAYOUTS / OUTWARD

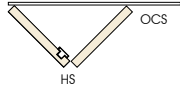
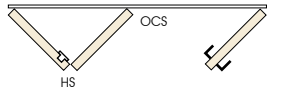
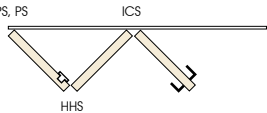
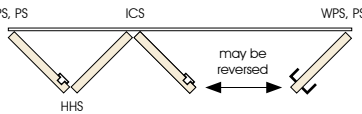
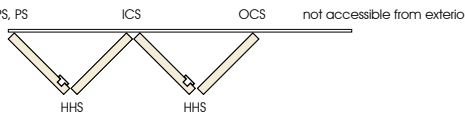
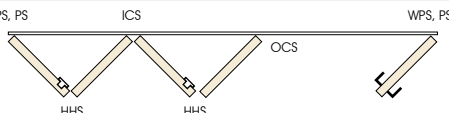
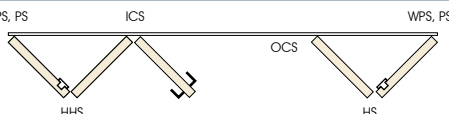
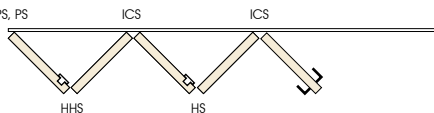
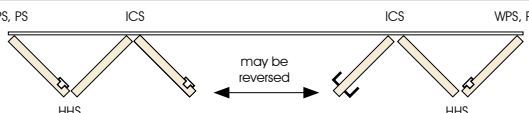
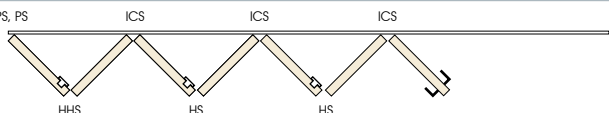
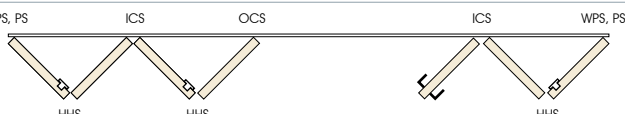
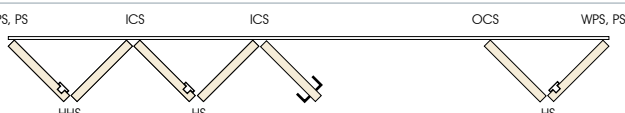
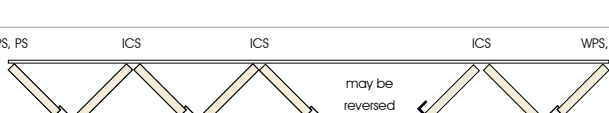
CODE	OPENING CONFIGURATION	HARDWARE
2L	inside WPS, PS not accessible from exterior outside 	1 x pivot set 1 x wall pivot set 1 x offset carrier set 1 x hinge set 2 x dropbolt
2L1R	inside WPS, PS WPS, PS outside 	2 x pivot set 2 x wall pivot set 1 x offset carrier set 1 x hinge set 2 x dropbolt
3L	inside WPS, PS ICS outside 	1 x pivot set 1 x wall pivot set 1 x intermediate carrier set 1 x half offset hinge set 2 x dropbolt
3L1R	inside WPS, PS ICS WPS, PS outside 	2 x pivot set 2 x wall pivot set 1 x intermediate carrier set 1 x half offset hinge set 4 x dropbolt
4L	inside WPS, PS ICS OCS not accessible from exterior outside 	1 x pivot set 1 x wall pivot set 1 x intermediate carrier set 1 x offset carrier set 2 x half offset hinge set 4 x dropbolt
4L1R	inside WPS, PS ICS WPS, PS outside 	2 x pivot set 2 x wall pivot set 1 x intermediate carrier set 1 x offset carrier set 2 x half offset hinge set 4 x dropbolt
3L2R	inside WPS, PS ICS WPS, PS outside 	2 x pivot set 2 x wall pivot set 1 x intermediate carrier set 1 x offset carrier set 1 x hinge set 1 x half offset hinge set 4 x dropbolt
5L	inside WPS, PS ICS ICS outside 	1 x pivot set 1 x wall pivot set 2 x intermediate carrier set 1 x hinge set 1 x half offset hinge set 4 x dropbolt
3L3R	inside WPS, PS ICS ICS WPS, PS outside 	2 x pivot set 2 x wall pivot set 2 x intermediate carrier set 2 x half offset hinge set 6 x dropbolt
7L	inside WPS, PS ICS ICS ICS outside 	1 x pivot set 1 x wall pivot set 3 x intermediate carrier set 2 x hinge set 1 x half offset hinge set 6 x dropbolt
4L3R	inside WPS, PS ICS OCS ICS WPS, PS outside 	2 x pivot set 2 x wall pivot set 2 x intermediate carrier set 1 x offset carrier set 3 x half offset hinge set 6 x dropbolt
5L2R	inside WPS, PS ICS ICS OCS WPS, PS outside 	2 x pivot set 2 x wall pivot set 2 x intermediate carrier set 1 x offset carrier set 2 x hinge set 1 x half offset hinge set 6 x dropbolt
5L3R	inside WPS, PS ICS ICS ICS WPS, PS outside 	2 x pivot set 2 x wall pivot set 3 x intermediate carrier set 1 x hinge set 2 x half offset hinge set 8 x dropbolt

E4 COMMON PANEL LAYOUTS / OUTWARD

CODE	OPENING CONFIGURATION	HARDWARE
2R	inside PS, WPS outside OCS HS not accessible from exterior	1 x pivot set 1 x wall pivot set 1 x offset carrier set 1 x hinge set 2 x dropbolt
1L2R	inside WPS, PS outside OCS HS	2 x pivot set 2 x wall pivot set 1 x offset carrier set 1 x hinge set 2 x dropbolt
3R	inside ICS outside WPS, PS HHS	1 x pivot set 1 x wall pivot set 1 x intermediate carrier set 1 x half offset hinge set 2 x dropbolt
1L3R	inside WPS, PS outside ICS HHS	2 x pivot set 2 x wall pivot set 1 x intermediate carrier set 1 x half offset hinge set 4 x dropbolt
2L2R	inside WPS, PS outside OCS HS not accessible from exterior	2 x pivot set 2 x wall pivot set 2 x offset carrier set 2 x hinge set 4 x dropbolt
1L4R	inside WPS, PS outside OCS HHS ICS HHS	2 x pivot set 2 x wall pivot set 1 x intermediate carrier set 1 x offset carrier set 2 x half offset hinge set 4 x dropbolt
4R	inside OCS outside ICS HHS WPS, PS not accessible from exterior	1 x pivot set 1 x wall pivot set 1 x intermediate carrier set 1 x offset carrier set 2 x half offset hinge set 4 x dropbolt
2L3R	inside WPS, PS outside OCS HS ICS HHS WPS, PS	2 x pivot set 2 x wall pivot set 1 x intermediate carrier set 1 x offset carrier set 1 x hinge set 1 x half offset hinge set 4 x dropbolt
5R	inside ICS outside ICS HS HHS WPS, PS	1 x pivot set 1 x wall pivot set 2 x intermediate carrier set 1 x hinge set 1 x half offset hinge set 4 x dropbolt
3L4R	inside WPS, PS outside ICS HHS OCS HHS ICS HHS WPS, PS	2 x pivot set 2 x wall pivot set 2 x intermediate carrier set 1 x offset carrier set 3 x half offset hinge set 6 x dropbolt
7R	inside ICS outside ICS HS HHS ICS HHS WPS, PS	1 x pivot set 1 x wall pivot set 3 x intermediate carrier set 2 x hinge set 1 x half offset hinge set 6 x dropbolt
2L5R	inside WPS, PS outside OCS HS ICS HS HHS ICS HHS WPS, PS	2 x pivot set 2 x wall pivot set 2 x intermediate carrier set 1 x offset carrier set 2 x hinge set 1 x half offset hinge set 6 x dropbolt
8R	inside OCS outside ICS HHS ICS HS HHS ICS HHS WPS, PS not accessible from exterior	1 x pivot set 1 x wall pivot set 3 x intermediate carrier set 1 x offset carrier set 2 x hinge set 2 x half offset hinge set 8 x dropbolt



STARTLING CARRYING CAPACITY

Larger and larger external openings; architecture which dismisses the mere notion of openness and strives for the real thing; sometimes even the vast possibilities of the E4 bifold system aren't quite enough. Other times design requirements limit lateral movement to a single plane, but still with the same high standard of performance and aesthetics. Centor E4S brings E4's robust good looks and startling carrying capacity to large scale openings of the sliding variety.

Further blurring the boundaries between indoor and outdoor space, the distinct attributes of E4S allow for even larger, more heavily constructed panels; complete walls of framed glazing that can be moved aside in seconds. With doors closed the large panels create an illusion of permanence, while views remain unobstructed and hefty frames are anchored solidly in place against the weather. Opened up, doors based on the E4S system allow for an unprecedented freedom of flow. Breezes, aromas, pedestrians, conversation; with E4S there's simply nothing to get in the way.

E4S Specifications	
max opening weight	400kg
max panel height	4000mm
max panel width	3000mm
max panel area	8m ²
min panel thickness	38mm

STARTLING CARRYING CAPACITY FOR LARGE SCALE SLIDING OPENINGS



E4S UP CLOSE

Allowing for the 'wow' factor in even the quietest environment, E4S creates a whole new range of possibilities for high-end architectural openings in both residential and commercial applications. Taken indoors E4S allows for substantial moveable partitions with acoustically appropriate materials for the office or home theatre environment and an operational feel that matches the slick look.

Adjustable Carriers

Four-wheeled carriers are fully articulated to ensure that all wheels share the load. Precision-ground stainless steel bearing wheels with nylon tyres make for an unprecedented smoothness of function for substantial sliding doors. Vertical adjustment enables perfect alignment of the panel and seals so that sight lines are beautifully catered for.

Floor Guides

A guide channel can be located in the base of the door for minimum disruption of the floors; alternatively for strength and security multiple guide points can be positioned on the base of the door running in a floor channel.

Design Flexibility

The operational ease and structural integrity of the E4S system allow for the system's use almost anywhere. The carrier and guide system E4S-based doors are built around allows for simple fixing to almost any substrate.

Lasting Quality

Constructed from stainless steel and engineering polymers, that beautiful first day impression will last a lifetime. Centor's reputation for reliable performance is kept intact by another premium product.

Specifying E4S

Architects and specifiers can feel comfortable simply specifying 'Centor E4S' and leaving detailed component selection to the builder, joiner or fabricator.



E4S PRODUCT DETAILS

Head Detail

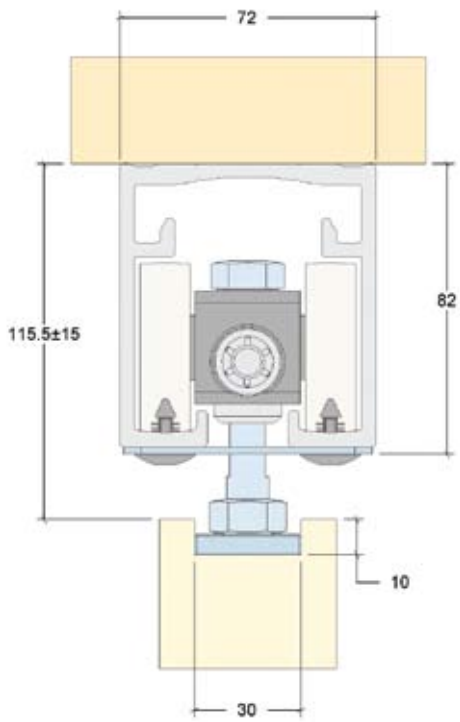

E4S-001.DXF

Door Preparation – Carriers

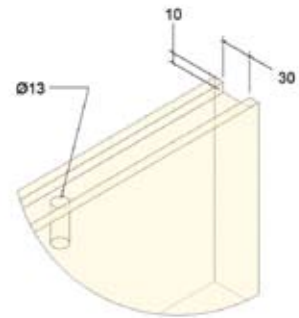

Door Preparation – Guide Channel

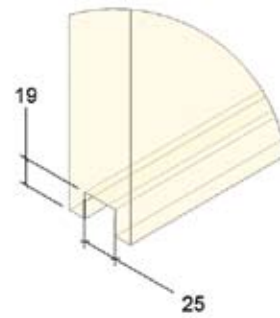

Guide Channel Concealed In Door

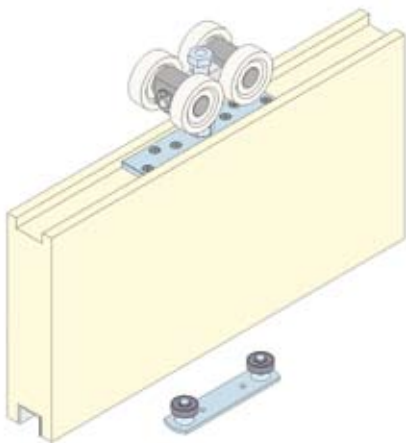

Guide Channel In Floor

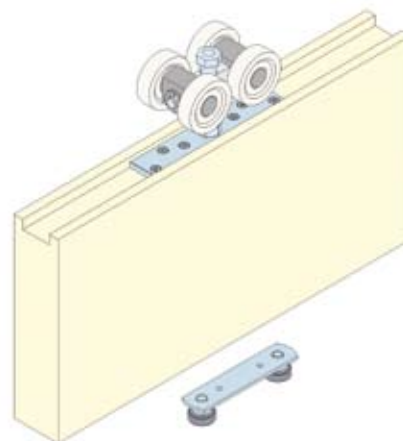

E4S COMPONENT SELECTION

E4S is specified with 5 separate component groups. Components are required from each group to build an E4S sliding door system except when indicated otherwise.

- 1 **Track** – choose surface finish, size and number required to suit opening
- 2 **Carriers** – choose number required to suit door frame and panel layout
- 3 **Guides** – choose guiding method and number required to suit panel layout
- 4 **Channel*** – choose material, surface finish, size and number required to suit opening
- 5 **Accessories** – choose items which best suit opening and door panel requirements

* Channels are an optional item.

TRACK







PART	TRACK	PRODUCT CODE	DESCRIPTION
	aluminium track, machined	E4TM4N	4000mm machined track, natural anodised
		E4TM6N	5700mm machined track, natural anodised

CHANNEL

PART	CHANNEL	PRODUCT CODE	DESCRIPTION
	straight channel 26mm	E2FCA2N	2000mm 19 x 26mm aluminium channel, natural anodised
		E2FCA3N	3000mm 19 x 26mm aluminium channel, natural anodised
		E2FCA4N	4000mm 19 x 26mm aluminium channel, natural anodised
		E2FCA6N	5700mm 19 x 26mm aluminium channel, natural anodised

E4S COMPONENT SELECTION

PARTS

PART	PRODUCT CODE	DESCRIPTION
	E44CCNSS	4 wheel carrier and mounting plate
	E4APC	access cover plate
	E4TJPA	track joining plate
	E4DS	door stop
	ATFGD	double roller guide, stainless steel precision stainless sealed bearing 22mm diameter
	ATFGS	single roller guide, stainless steel precision stainless sealed bearing 22mm diameter

While every effort has been made to ensure the accuracy of the information in this publication, Centor Architectural assume no responsibility for errors or omissions or any consequences of reliance solely on this publication.



Centor Australia Pty Ltd

ABN 96 009 716 189
telephone 1300 CENTOR
1300 236 867
facsimile 1300 CENFAX
1300 236 329
mail@centor.com.au
www.centor.com.au

BRISBANE

Centor Australia Pty Ltd
Head Office & Factory
997 Kingsford Smith Drive
PO Box 1550
Eagle Farm QLD 4009
telephone +61 7 3868 5777
facsimile +61 7 3868 1201

SYDNEY

Centor Australia Pty Ltd
12/9 Killo Crescent
Glendenning NSW 2761
telephone +61 2 9208 3200
facsimile +61 2 9625 2399

MELBOURNE

Centor Australia Pty Ltd
28 Keysborough Close
Keysborough VIC 3173
telephone +61 3 9709 0300
facsimile +61 3 9798 1645

ADELAIDE

Centor Australia Pty Ltd
Unit 4, 2 Endeavour Drive
PO Box 285
Port Adelaide SA 5015
telephone +61 8 8304 2577
facsimile +61 8 8304 2599

PERTH

Notchka Pty Ltd
45 Colray Avenue
Osborne Park WA 6017
telephone +61 8 9443 3266
facsimile +61 8 9443 3250
sales@notchka.com

TASMANIA

Launceston
Access Hardware Pty Ltd
42 Invermay Road
Mowbray Heights TAS 7248
telephone +61 3 6331 2533
facsimile +61 3 6331 2733
accesshw@bigpond.net.au

Hobart

Access Hardware Pty Ltd
21 Brisbane Street
Hobart TAS 7000
telephone +61 3 6231 9926
facsimile +61 3 6231 9927



204-100-030-002